

ON 3D-FEM ANALYSIS OF A 9000 TDW TANKER GLOBAL EIGEN VIBRATION MODES

Dumitru-Silviu Perijoc

"Dunarea de Jos" University of Galati,
 Faculty of Naval Architecture, Galati,
 47 Domneasca Street, 800008, Romania,
 E-mail: silviu.perijoc@ugal.ro

Leonard Domnişoru

"Dunarea de Jos" University of Galati,
 Faculty of Naval Architecture, Galati,
 47 Domneasca Street, 800008, Romania,
 E-mail: leonard.domnisoru@ugal.ro

ABSTRACT

Identifying a vessel global eigen vibration modes during the early stages of the design process is necessary, as it allows the prediction of special phenomena such as springing, whipping or other different resonance condition, that can lead to an uncomfortable working environment or, in extreme cases, even damage to the structure or equipment. An advanced approach for assessing the ships' eigen vibration characteristics is based on the 3D-FEM method. This research is focused on analysing the eigen global vibration frequencies, for vertical, horizontal, and torsion modes, of a 9000 tdw tanker, pointing out the influence of the surrounding water by hydrodynamic added masses formulation.

Keywords: global vibration eigen modes analysis, 3D-FEM tanker model.

1. INTRODUCTION

The current paper focuses on the subject of the global natural vibration analysis of a 9000 tdw oil-tanker (see references [2],[7] for the prototype). The structural vibrations inevitably occur in a ship's exploitation time, due to periodic or random waves' and equipments' loads. If the external loads have close frequencies to that of the natural frequency of the ship, then the admissible vibration levels may be exceeded. Generally, the problems related to the global and local vibrations can lead to: structural fatigue, equipments' damage, high noise. Therefore, at the preliminary design stage, the problem of global vibrations can be solved according to the hydrodynamic characteristics, the ship's and the propulsion layouts. For ships, the main vibration excitations are: sea waves, main engine, propeller and other equipments.

The present paper deals only with the hull girder global natural vibration modes. The modal analysis is done using the Siemens Femap/NX Nastran program [1], with the Lanczos method for eigen modes computation.

2. THE 9000 TDW OIL TANKER DESCRIPTION

The modal analysis is done for a 9000 tdw oil-tanker with the main dimensions in Table 1 and 3D-CAD shape in Fig.1. The structure scantlings are obtained by means of the DNV-GL Poseidon [3] program and the hull rules [4], with the midship characteristics from Figs.2-5.

Table 1. The 9000 tdw tank main dimensions

L_{OA} [m]	124.87	d [m]	6.20
L_{pp} [m]	120.00	Δ [t]	13143
B [m]	21.60	v [knots]	15
D [m]	9.10	ρ [t/m ³]	1.025

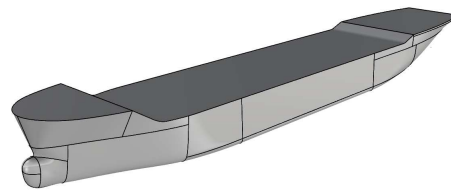

Fig.1 The 3D-CAD shape of 9000 tdw tanker

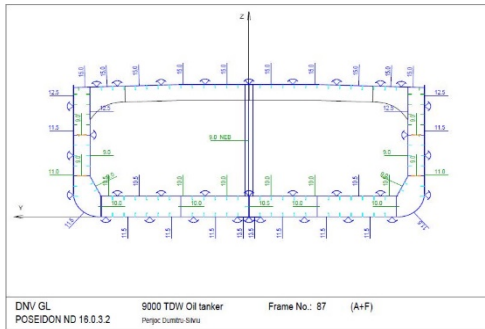

Fig.2 Shell thickness, 9000 tdw oil-tanker

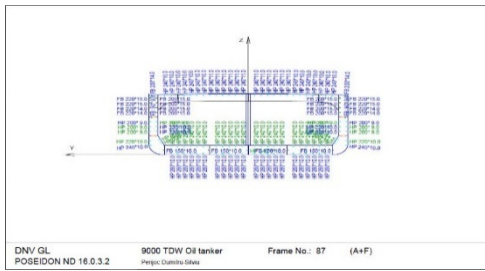

Fig.3 Profile dimension, 9000 tdw oil-tanker

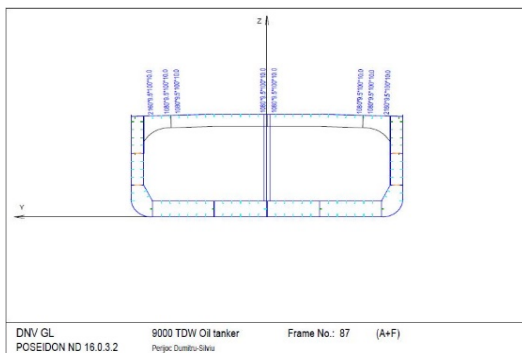

Fig.4 Transversal girders, 9000tdw oil-tanker

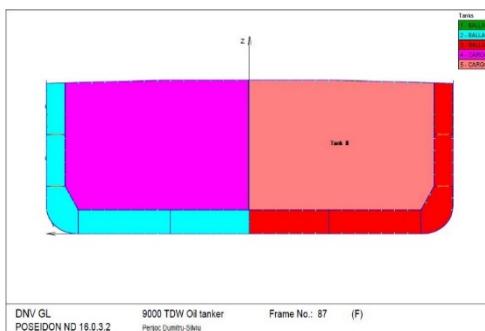

Fig.5 Cargo and ballast tanks arrangement

3. The 3D-FEM MODEL OF THE 9000 TDW OIL TANKER

First, for the 9000 tdw oil tanker ship, we have designed a 3D-CAD simplified structural model, without local details, using the Femap/NX Nastran [1] 3D modelling options, presented in Figs.6.a-g.

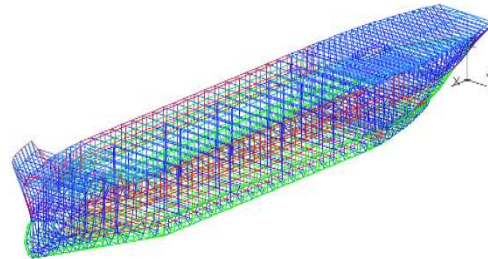

Fig.6.a 3D-CAD model, 9000 tdw tanker

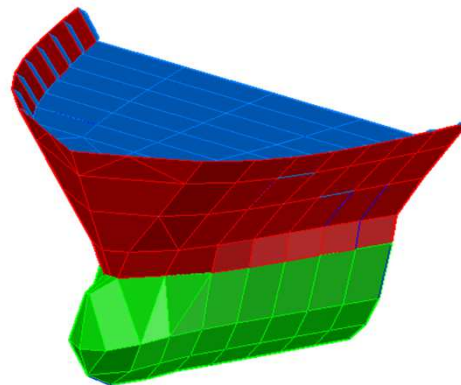

Fig.6.b 3D Geometry fore part shells

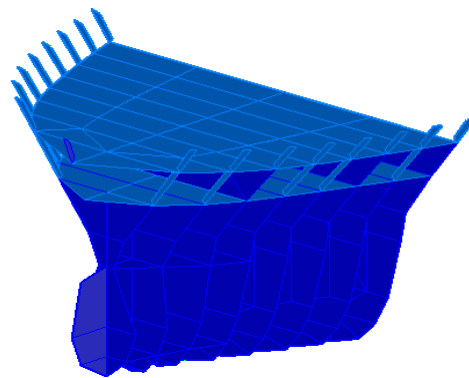

Fig.6.c 3D Geometry fore part detail

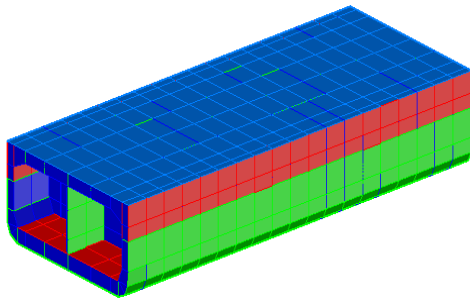

Fig.6.d 3D Geometry cargo-hold shells

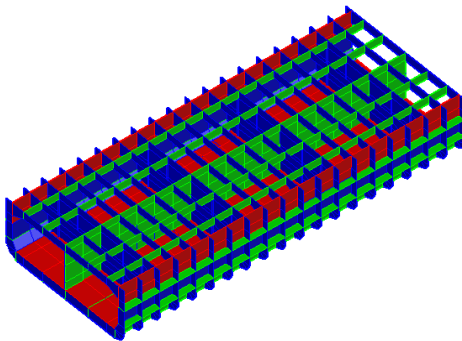

Fig.6.e 3D Geometry cargo-hold detail

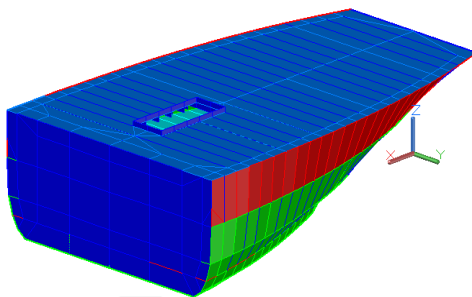

Fig.6.f 3D Geometry aft part shells

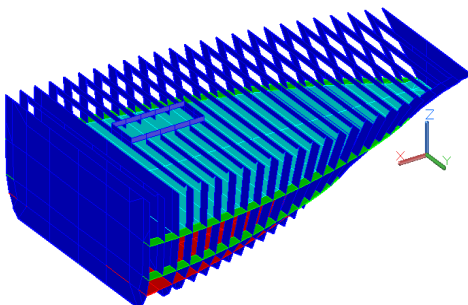

Fig.6.g 3D Geometry aft part detail

Based on the 3D-CAD model of the 9000 tdw oil-tanker (Figs.6.a-g), the numerical 3D-FEM model was developed by means of the Femap /NX Nastran [1] program meshing options. The hull is made of steel, with the characteristics presented in Fig.7.

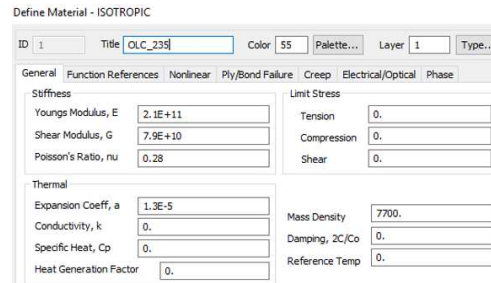

Fig.7 Material properties, steel A grade

The geometry was meshed with triangular PLATE elements [5], using the auto mesh option from Femap/NX Nastran [1], resulting a total of 38231 nodes and 86194 elements.

The modal analysis was performed for hull structure in two conditions: dry and with hydrodynamic added masses (hyd.).

The hydrodynamic added masses are introduced in the 3D-FEM model as non-structural mass per unit of area, on the immersed shell and inner shell tanks structure.

The cargo and hydrodynamic added masses for longitudinal (11), lateral (22), vertical (33) and torsion (44) vibrations, are computed by the Lewis method [5],[6] and are presented in Tables 2-6.

Table 2. Cargo masses

Cargo	9000	t
EL.AREA	2578.1	m ²
Mass/Area unit	3.49	t/m ²

Table 3. M11 hydrodynamic added mass

M11	1276.6	t
EL.AREA	3125.7	m ²
M11/EL.AREA	0.409	t/m ²

Table 4. M22 hydrodynamic added mass

M22	11654.61	t
A	3125.71	m ²
M22/EL.AREA	3.73	t/m ²

Table 5. M33 hydrodynamic added mass

M33	22535.78	t
A	3125.71	m ²
M33/EL.AREA	7.21	t/m ²

Table 6. M44 hydrodynamic added mass

M44	391214.2	t
A	3125.71	m ²
P44/EL.AREA	1.3	t/m ²

Figs.8.a-h present the details of the 3D-FEM structural model for the 9000 tdw oil tanker, fore, cargo-holds and aft parts.

The 3D-FEM model is fully extended over the tanker structure, so that for the free vibration analysis no boundary conditions are required.

For the modal analysis the searching frequency range is selected between 0.1 Hz and 7 Hz, using for the eigen modes solution by the Lanczos method, implemented in the Femap/NX Nastran [1] program.

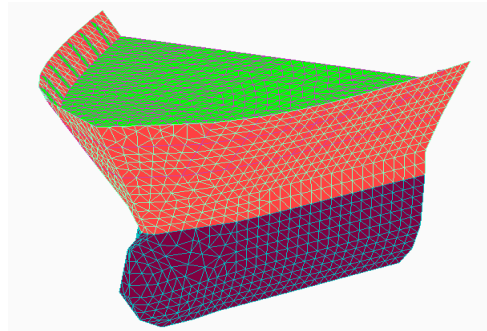

Fig.8.c 3D-FEM structure, fore part shell

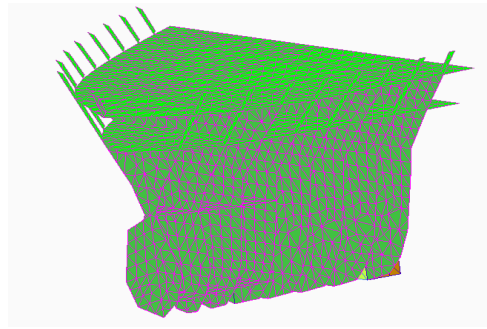

Fig.8.d 3D-FEM structure, fore part detail

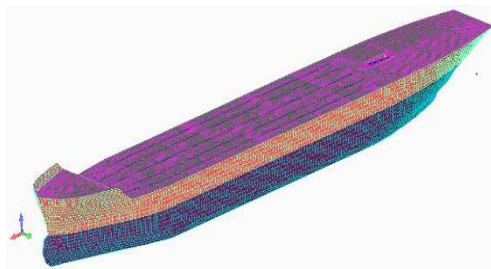

Fig.8.a 3D-FEM full model, 9000 tdw tanker

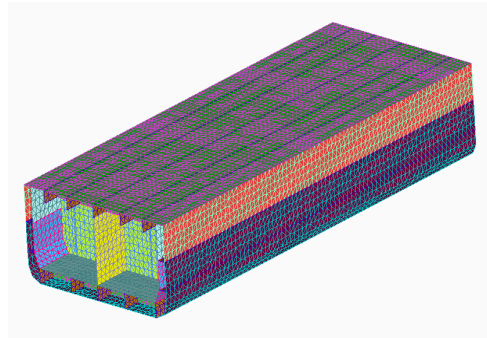

Fig.8.e 3D-FEM cargo-holds shell

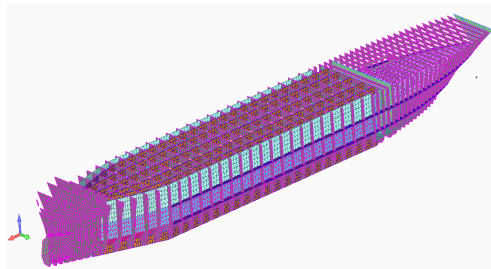

Fig.8.b 3D-FEM full model, frames & girders

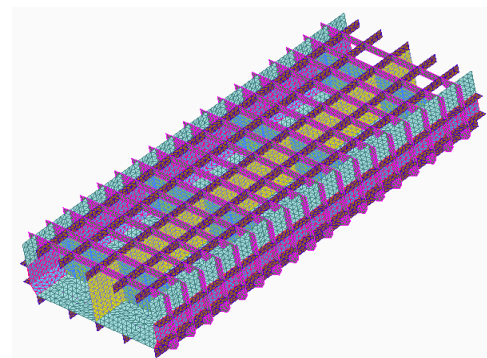

Fig.8.f 3D-FEM cargo-holds detail

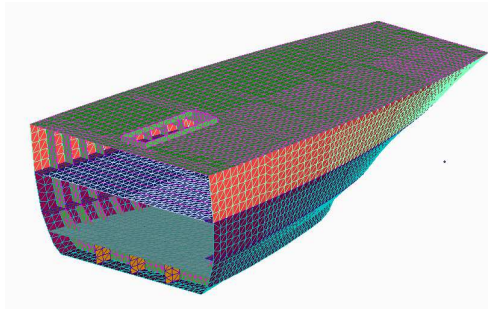

Fig.8.g 3D-FEM structure, aft part shell

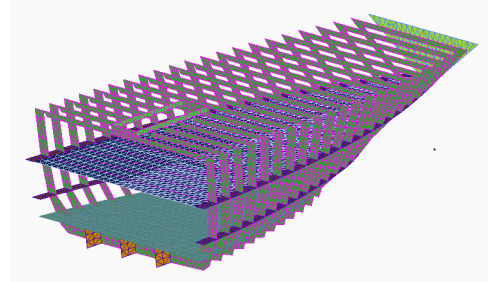

Fig.8.h 3D-FEM structure, aft part detail

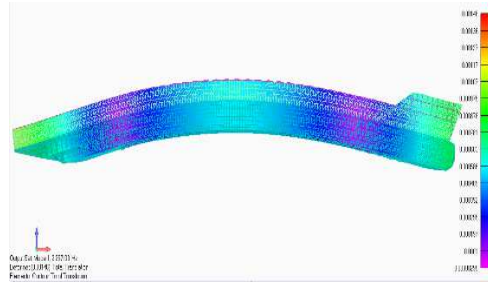

Fig.9.b The first vertical global natural mode, hyd. 2.27 Hz

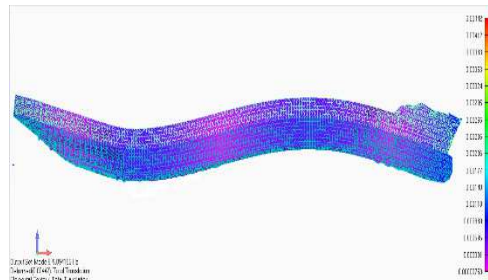

Fig.9.c The second vertical global natural mode, dry 5.09 Hz

4. NUMERICAL RESULTS

The global natural frequencies for the 9000 tdw oil-tanker obtained in the range of 0.1-7 Hz are presented in Table 7.

The free global vibration modal forms, corresponding to the natural frequencies from Table 7 are presented in Figs. 9.a-h.

Table 7. Global vibration eigen modes

GLOBAL VIB. MODE	DRY [Hz]	HYD. [Hz]	DIFF. [%]
Vertical 1	2.34	2.27	-3.2
Horizontal 1	4.69	4.30	-8.2
Vertical 2	5.09	4.90	-3.8
Torsion 1	5.83	5.74	-1.6

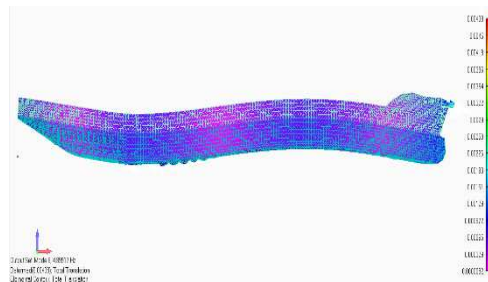

Fig.9.d The second vertical global natural mode, hyd. 4.90 Hz

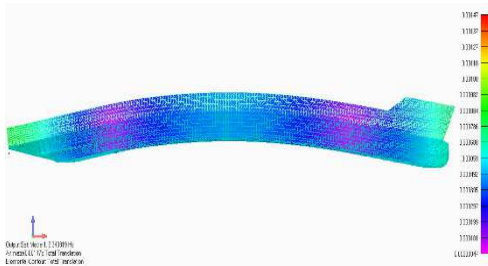

Fig.9.a The first vertical global natural mode, dry 2.34 Hz

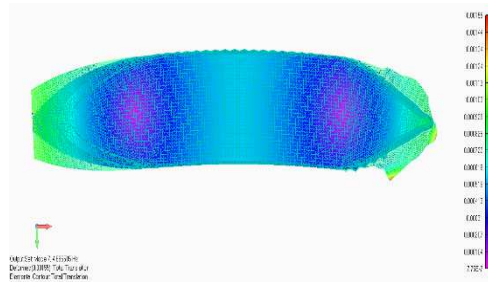

Fig.9.e The first horizontal global natural mode, dry 4.69 Hz

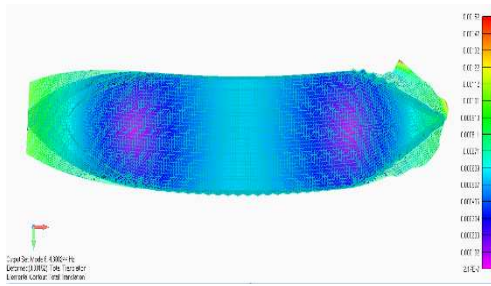

Fig.9.f The first horizontal global natural mode, hyd. 4.30 Hz

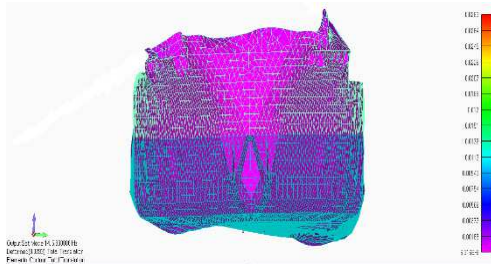

Fig.9.g The first torsion global natural mode, dry 5.83 Hz

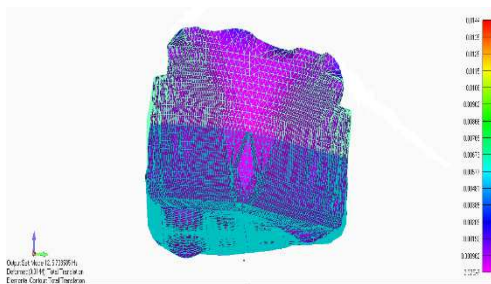

Fig.9.g The first torsion global natural mode, hyd. 5.74 Hz

5. CONCLUSIONS

The analysis performed on the 3D-FEM model shows that the hydrodynamic added masses lead to a decrease of the global natural vibration frequencies and, for the considered displacement case, the results are as follows:

- vertical eigen values differences of 3.14% (1-mode) and 3.82% (2-mode);
- horizontal eigen value differences of 8.22% (1-mode);
- torsion eigen value differences of 1.56% (1-mode).

From the numerical results obtained within the analysed frequency range (0.1-7 Hz), it can be observed that the 9000 tdw oil-tanker second horizontal, torsion and longitudinal eigen modes could not be identified. Among the global modes, many local vibration modes have been obtained (not included in the list of results).

The current arrangement of the structure of the 9000 tdw oil-tanker seems to lead to an excessive rigidity, with high global frequency vibration modes.

Further investigations with regards to the 9000 tdw oil-tanker global vibration modes should be taken into consideration, due to changes that might be made for the whole tanker hull structure, according to the rules strength safety criteria [4], and other displacements for different cargo load cases.

Acknowledgements

This study is developed in the frame of the Naval Architecture Research Centre, "Dunarea de Jos" University of Galati.

REFERENCES

- [1]. **FNN**, "Femap/NX Nastran users' manual", Siemens PLM Software Inc., 2019.
- [2]. **JSEA**, "Marine engineering in Japan", Japan Ship Exporters' Association, 1993-2019, <https://www.jsea.or.jp>
- [3]. **DNV-GL**, "Poseidon program users' manual", Det Norske Veritas and Germanischer Lloyd, 2019.
- [4]. **DNV-GL**, "Hull structure rules", Det Norske Veritas and Germanischer Lloyd, 2019, <https://www.dnvgl.com>
- [5]. **Domnisoru, L.**, "Structural analysis and hydroelasticity of ships", The University Foundation "Dunarea de Jos" Publishing House, Galati, 2006.
- [6]. **Domnisoru, L.**, "Special chapters on ships' structure analysis. Applications", The University Foundation "Dunarea de Jos" Publishing House, Galati, 2017.
- [7]. **Dumitru, D.**, "Compendium of ships forms", "Dunarea de Jos" University Foundation Publishing House, Galati, 2014.

Paper received on October 20th, 2019